

CDT 30S-40S MKIII

Service manual

Rev. 1.0

Dantherm[®]
CONTROL YOUR CLIMATE

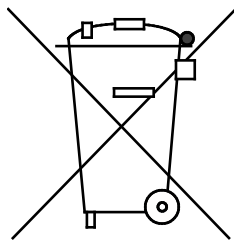

Der tages forbehold for trykfejl og ændringer
Dantherm can accept no responsibility for possible errors and changes
Irrtümer und Änderungen vorbehalten
Dantherm n'assume aucune responsabilité pour erreurs et modifications éventuelles

Introduction

Overview

Contents

This manual contains the following sections:

Introduction.....	1
Overview.....	1
General warnings	3
Setup and user guide	4
Product and function descriptions	4
Preparation and transportation guide	7
User guide	11
Accessories.....	17
Service guide	18
Preventive maintenance.....	18
Troubleshooting	25
Disposal	26
Appendix.....	27
Technical data	27
Dimensions.....	28
Wiring diagram	29
Declaration of Conformity	30
Index.....	31

Continued on next page

Overview, *cont.*

Dehumidifiers	This manual concerns Dantherm transportable dehumidifier type: CDT 30S MK III item number 351111 CDT 40S MK III item number 351113
Warning	Please ensure you read this service manual, and use the correct operating and maintenance procedures. Read the entire manual before using the dehumidifier. Awareness of the correct operating procedure for the machine and its safety devices is important, to avoid damage or injury.
Target group	This manual is intended for users and technicians performing preventive maintenance and repairs. The appliance can be used by children aged from 8 years and above and persons with reduced, physical, sensory or mental capabilities or lack of experience and knowledge if they have been given supervision or instruction concerning use of the appliance in a safe way and understand the hazards involved. Children shall not play with the appliance. Cleaning and user maintenance shall not be made by children without supervision.
Copyright	Copying all or parts of the manual is forbidden without the written consent of Dantherm.
Provisos	Dantherm reserves the right to make changes and improvements to the product and in the service manual at any time, without prior notification or obligation.

General warnings

Warning:

The dehumidifiers contain a flammable refrigerant. Take following precautions in order to avoid any danger:

Point of awareness:

- Be aware that refrigerants may not contain an odour.

Location requirement (installation and storage):

- The appliance shall be installed, operated and stored in a room with a floor area larger than 4m². Check if there are any local regulations, you must comply to, when installing or storing the appliance.
- The appliance shall be stored in a room without continuously operating ignition sources (for example: open flames, an operating gas appliance or an operating electric heater.)
- Keep the ventilation openings clear of obstruction during operation.

Actions to avoid (operation and handling):

- Be especially careful when handling the unit, not to cause any damage that may result in leakage of the cooling circuit.
- Do not use means to accelerate the defrosting process or to clean, other than those recommended by the manufacturer.
- Do not pierce or burn.

In case of fire:

- Toxic fumes may occur in the event of fire. Thus you must leave the room as quick as possible in the case of fire.
-

Setup and user guide

Product and function descriptions

Introduction

This section provides a product description of the CDT 30S/40S MKIII, plus a description of its functionality.

How it works

Air flow through the dehumidifier:

How the air changes as it passes through the dehumidifier:

The fan draws humid air through a filter inside the dehumidifier.



The air is cooled, causing the moisture content to condense into drops of water, which are collected in the water container.



The air is reheated using heat from the dehumidifier's operation (temperature increase of approx. +5 °C), and the option of further heating using the integrated heating element.

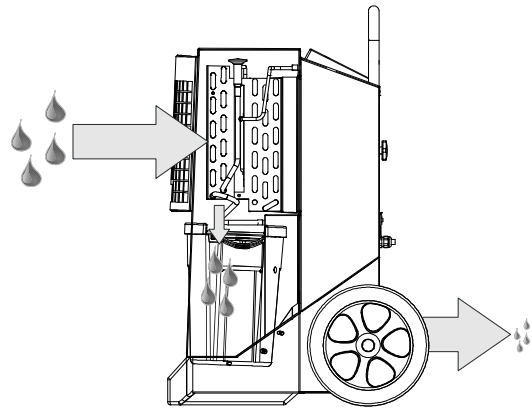

As the air is repeatedly circulated through the dehumidifier, its moisture content is repeatedly reduced, resulting in rapid, gentle drying. The dehumidifier can run constantly, or be controlled by a built-in hygostat.

Illustration

Illustration of dehumidifier:

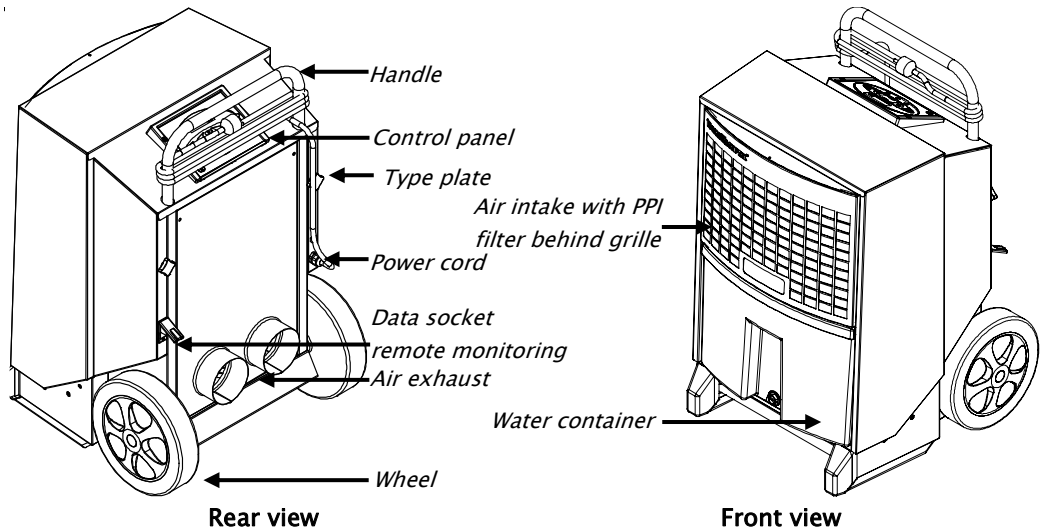

Continued on next page

Product and function descriptions, *cont.*

Ducting connections With two hoses (2 x 100 mm dia.) on the exhaust, dry, hot air can be passed under a surface such as a floor.
Dantherm recommends connection of max. 5 metres of flexible ducting per connection spigot.

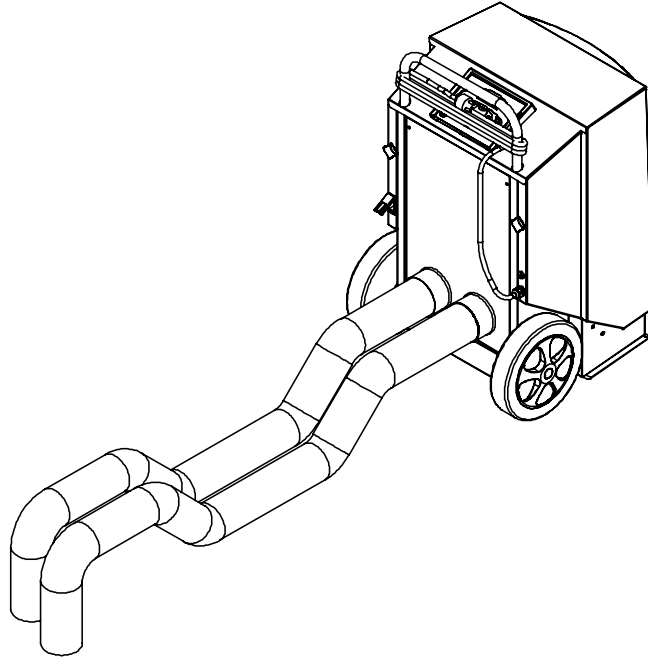

Heating element CDT 30S/40S has one 1 kW integrated heating element. When the element is active, the dehumidification process is accelerated. See page 11 of the user guide for heating element operation.

Water container Condensate water is collected in the water container or it can be piped to a drain via a hose spigot (optional accessory).
The dehumidifier cuts out automatically when the container is full. See the user guide for emptying the water container. The dehumidifier cannot operate when the container is removed.

Continued on next page

Product and function descriptions, *cont.*

Control panel

Illustration of control panel:

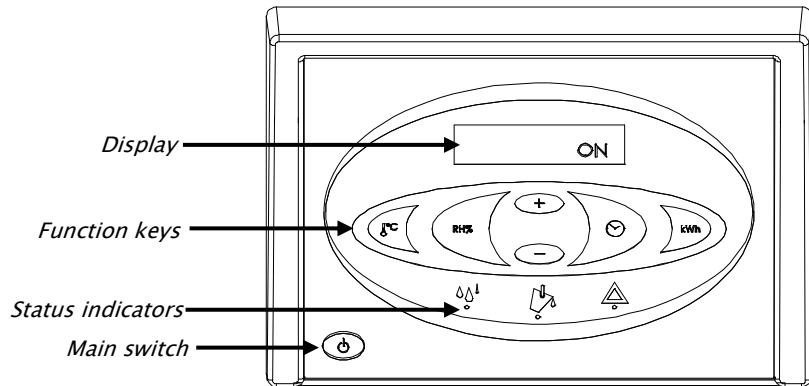

Functions

Main functions:

- Manual or auto (built-in adjustable hygrostat).
- External hygrostat socket.
- Display of temperature, relative air humidity, hours and kWh consumption.
- Hour counter and kWh consumed without 230V connection.
- Adjustable service interval counter.
- Supply of extra heat for higher dehumidification efficiency.
- Targeted dehumidification, e.g. between floor decks.

Operation described in the user guide in this manual.

Cooling circuit diagram

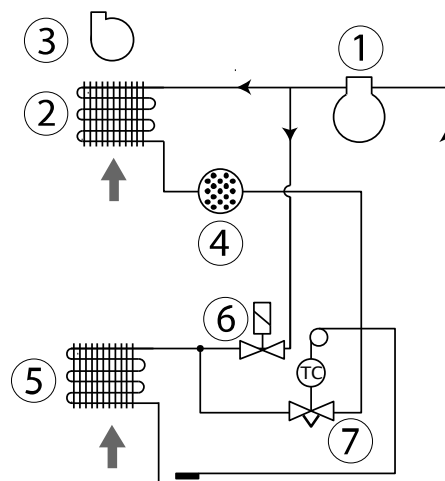

Pos.	Description	Pos.	Description
1	Compressor	5	Evaporator
2	Condenser	6	Solenoid
3	Fan	7	Thermostatic expansion valve
4	Dry filter		

Preparation and transportation guide

Introduction

This section is a guide to unpacking, preparation, transport and storage

Warning

If the machine has been transported lying down, allow it to stand upright for at least 1 hour before use.

Unpacking

Follow these steps for unpacking:

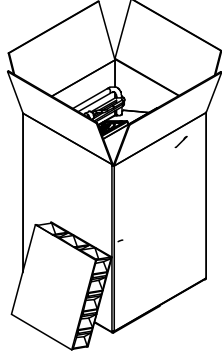
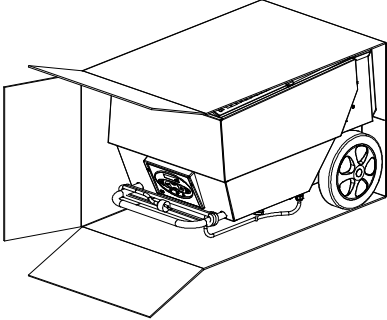
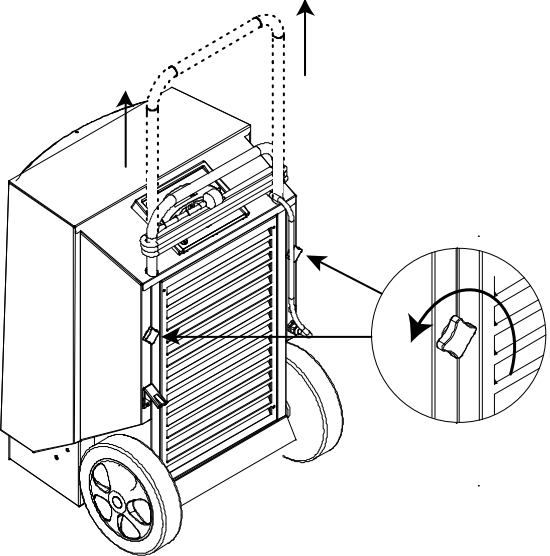
Step	Action	Illustration
1	Open the top of the packaging	
2	Position the box vertically, with the wheels at the bottom	
3	Extract the machine from the box	
4	Loosen the knobs, pull the handle up to the desired height and retighten the knobs	
5	Remove the protective foil on the control panel	

Continued on next page

Preparation and transportation guide, *cont.*

Position

Position the dehumidifier where there is plenty of air circulation around it, with minimum 60 cm of clearance on the air intake side, and 3 meters of clearance on the exhaust side if no flexible ducts are attached. Remember also:

- To keep ventilation openings clear of obstruction during operation.

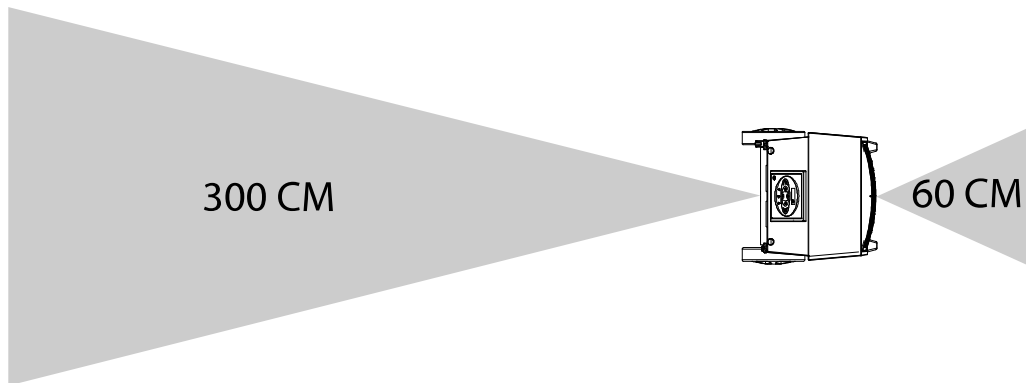

Location requirements

Since the dehumidifiers contain a flammable refrigerant following location requirements must be fulfilled:

- The appliance shall be installed, operated and stored in a room with a floor area larger than 4m². Check if there are any local regulations, you must comply to, when installing or storing the appliance.
- The appliance shall be stored in a well-ventilated area, where the room size corresponds to the room area of 4m².
- The appliance shall be stored in a room without continuously operating ignition sources (for example: open flames, an operating gas appliance or an operating electric heater.)

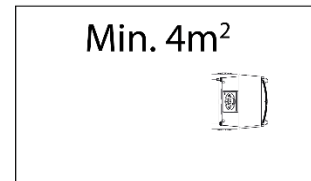

Optimum operation Ensure the room to be dehumidified is sealed, and that the machine is not located near a heat source, such as radiators.
If flexible ducts are attached, performance will be significantly impaired if they exceed 5 metres in length.

Electrical connection The machine comes complete with a 3.5m power cord, and can be connected to any 230 V, 50 Hz socket with a 10-16A fuse.
If the plug has 3 pins incl. PE-connection a plug adapter (accessory - item no. 396249) has to be used.

Warning: If the supply cord is damaged, it must be replaced by the manufacturer, its service agent or similarly qualified persons in order to avoid a hazard.

Preparation and transportation guide, *cont.*

Transporting or moving the dehumidifier

The machine can be moved by two people or using a crane. See the instructions below: Be aware of any local safety regulations with regard to lifting!

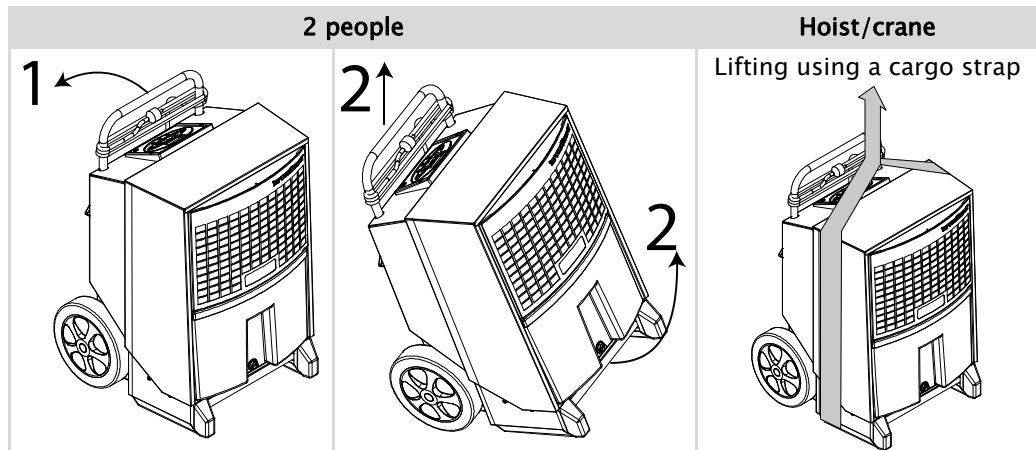

Stairs

The wheels are positioned such that the machine can be pulled upstairs without damage to the cabinet or stairs.

Continued on next page

Preparation and transportation guide, *cont.*

Storage

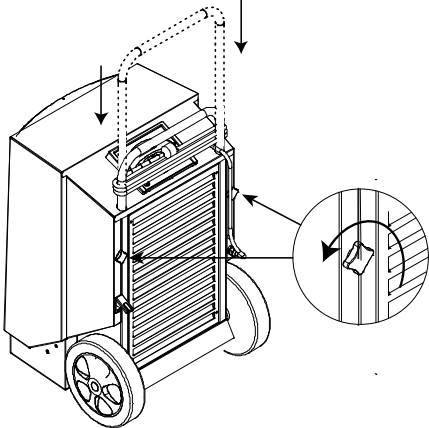
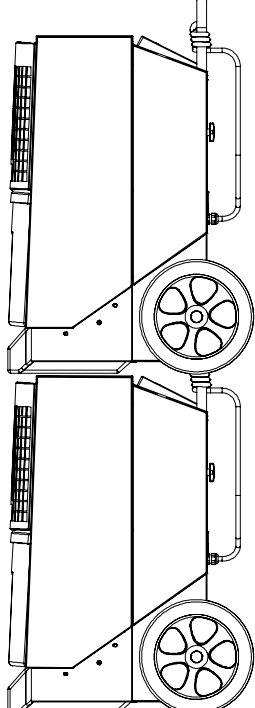
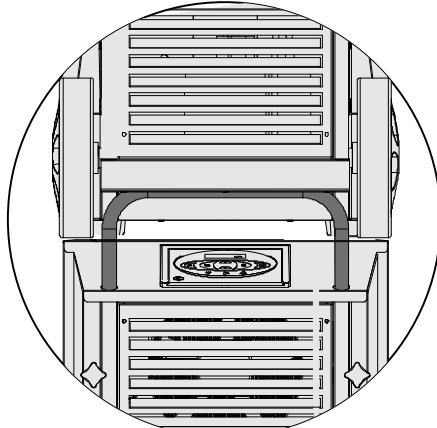

Do not stack more than 2 high.

Step	Illustration
Push handle down.	 A line drawing of a Dantherm portable air conditioner unit. A dashed line with an arrow indicates the handle being pushed down into the top of the unit. A circular inset on the right shows a close-up of the handle's end fitting into a slot on the unit's frame.
Stack units.	 A line drawing showing two Dantherm portable air conditioner units stacked vertically. The top unit is resting on the handle of the bottom unit. The wheels of the bottom unit are visible at the base.
Check that the upper set of wheels are placed correctly on the handle below.	 A circular inset illustration showing a top-down view of the stacked units. The wheels of the upper unit are shown resting on the handle of the lower unit. Arrows point to the contact points between the wheels and the handle.

User guide

Switching on/off and operating status

The table below shows operation of the on/off function and display texts.

Key	Display
	ON - constant
	INT HYG ON - operation controlled by internal hygostat
	INT HYG STOP, if internal hygostat set point is reached
	EXT HYG ON - operation controlled by external hygostat
	EXT HYG STOP, if external hygostat set point is reached
	Switch off
	The green LED indicates active dehumidification

Operating the heating element

The integrated 1 kW heating element is activated by setting the switch behind the water container to setting **1**. Switch to **0** to deactivate.

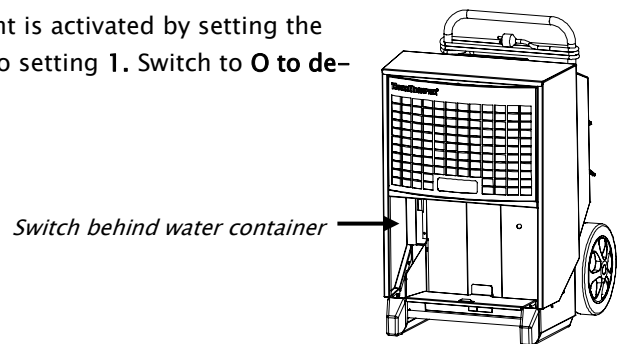



Continued on next page

User guide, *cont.*

Internal hygrostat operation

The table below shows operation of the hygrostat function and display texts.

Step	Key	Feedback
Press and hold		HYG SET RHxxx% – will flash for 5 seconds. The dehumidifier will then switch to internal hygrostat controlled operation with set point (once the set point is reached, the display will show INT HYG STOP)
Press (when flashing)		Press +/- briefly when flashing to set the RH% value. The new value will be saved after a further 5 second period after the last key is pressed.
		HYG OFF will flash. Setting is stored after 5 seconds. The dehumidifier will then switch to constant operation.



External hygrostat operation

If an external hygrostat is connected, the machine will automatically switch over to using it

Any adjustment of the set point must now be made on the external hygrostat. (once the set point is reached, the display will show **EXT HYG STOP**)

Hour counter

The built in hour counter logs the total number of operating hours (cannot be reset) and the number of hours left until the next service, which can be adjusted. The service hour counter is disabled upon delivery.





Step	Key	Feedback
Press and hold		SERVICE xxxxh – shows the number of hours to the next authorised service. This value is saved automatically after 5 seconds of flashing, and the function will activate if not already activated. When the set number of hours for service intervals has expired, the display will switch to SERVICE
		Press +/- briefly to set a new service value. The new value will be saved 5 seconds after the last key is pressed
Press		SET SERVICE OFF – deactivates the service timer function

Continued on next page

User guide, *cont.*





Display texts

The table below shows how to operate the operating information functions

Key	Feedback
	XX°C – shows the current room temperature
	Actual RH% – shows the actual relative air humidity value measured
	XX kWh – shows total energy consumption. Cannot be reset
	xxxxh – shows the total number of operating hours for the machine. Cannot be reset

Text displays when not connected to mains

The machine has a built-in battery to allow reading text displays when not connected to the mains. The following texts can be read when not connected to the mains:

Key	Feedback
 hold down and  press once	Displays total energy consumption in kWh
 hold down and  press once	Shows total number of operating hours for the dehumidifier

Continued on next page

User guide, *cont.*

Replacing the memory battery

If the hour counters cannot be read when disconnected from mains, it is probably due to flat memory battery. Replacement procedure:

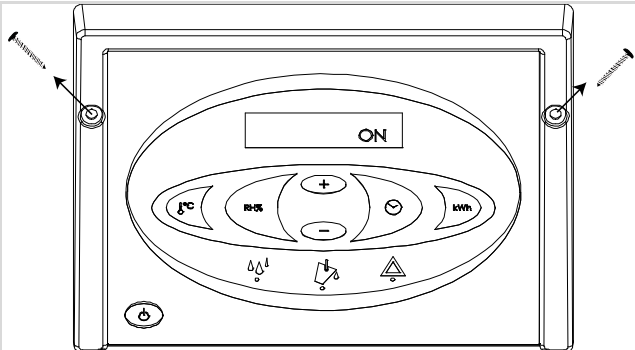

Action	
Warning: Always disconnect from the mains before changing battery	
1	<p>Slacken the screws on both side of the control panel, and carefully lift the panel up using the top edge</p> 
2	<p>Cut the cable tie holding the battery. Replace the battery, using a new cable tie max. 2.5 mm wide. Use Alkaline AAA batteries only Illustration of PCB with battery included in the wiring diagram on page 29.</p>

Continued on next page

User guide, *cont.*

Error messages

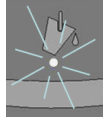
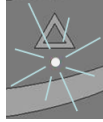
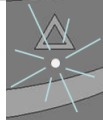
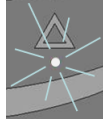
An overview of possible errors which prevent normal operation

Error message	Illustration	Cause	Remedy
Yellow light on centre LED with emptying symbol and FULL on display		Water container full	See guide below for emptying
Red light on right warning LED HIGH TEMP on display		Pressure or temperature in high pressure element too high	Check filter and dehumidifier for dirt in airways
Red light on right warning LED AMBI-ENT TEMP on display		Room temperature out of normal range	Place the dehumidifier in the specified temperature range, between 3°–32°C
Red light on right warning LED SENSOR FAIL on display. One of the internal sensors is defective. Use the +/- keys to toggle between 3 possible errors		SENSOR FAIL	
		1: EVAP FAIL Evaporator thermometer defective	Requires an authorised service technician
		2: COND FAIL Condenser thermometer defective	Requires an authorised service technician
		3: ROOM FAIL The internal room thermometer is defective	Requires an authorised service technician
Red light on right warning LED LP STOP on display		Leak in cooling circuit	Requires an authorised service technician

Continued on next page

User guide, *cont.*

Emptying the water container The dehumidifier does not need to be switched off when emptying the container. The dehumidifier will switch off automatically when the water container is removed.

Water container emptying procedure:

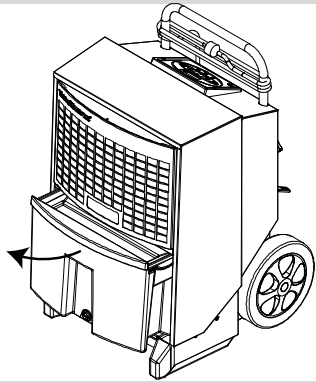
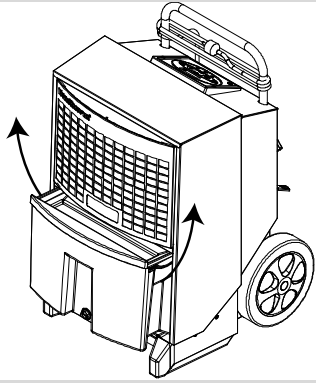
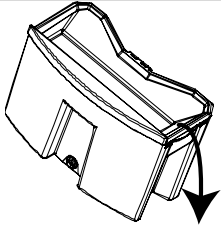
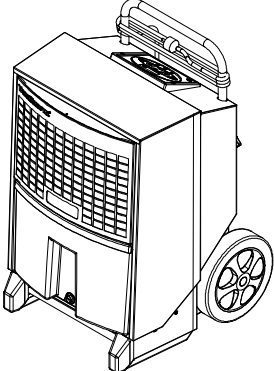
Step	Action	Illustration
1	Pull the water container halfway out by pulling the handle on its front	
2	Grip the water container side handles, and lift free of the dehumidifier	
3	Empty the water container by tipping the water out of the spout on the side	
4	Replace the water container Important: Check that the water container is pushed in as far as it will go	





Accessories

Introduction

More details of each accessory can be obtained from Dantherm.

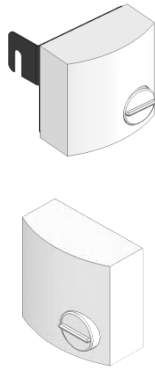
List

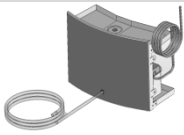
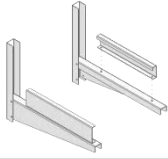
To follow is a complete list of accessories for the CDT range, with illustrations, description and item number:

Accessories	Illustration	Description	CDT-type	Item no.
Hygrostat		With a hygrostat connected, the dehumidifier can run automatically depending on actual air humidity		
		Hygrostats come in two versions: Hygrostat with 0.4 m power cord, jack plug and bracket	All	396242
		Hygrostat with 3 m power cord and jack plug	All	396241
Valve and hose thread		Ball valve, brass hose thread and jubilee clip	All	396243
Condensed water pump		If a condensation pump is used, emptying the water container is not necessary	CDT 30/30S	075616
			CDT 40/40S/60	075617
Wall bracket		The dehumidifier can be kept clear of the floor if mounted on the wall bracket	CDT 30/30S	396247
			CDT 40/40S/60	396248
Danish plug with earth pin		Adapter for continental plugs with earth	All	396249

Service guide

Preventive maintenance

Warning

Preventive maintenance is necessary to prevent breakdowns.
Always disconnect from the mains before servicing the machine!

This product contains flammable refrigerant. Prior to work on the system conduct the following safety checks to minimize the risk of fire:

- No open flames
- No electrical ignition sources (open electrical contacts)
- No mechanical ignition sources (grinding processes)
- No flammable material near the workspace
- Good ventilation of the area
- Check for presence of refrigerant

Other safety measures:

- Technicians and others working in the local area must be instructed of the nature of work been carried out.
- The area around the workspace must be sectioned off.
- Put up a "No smoking" sign around the section.

If any hot work is to be conducted on the refrigerant equipment or any associated parts, appropriate fire extinguishing equipment must be available at hand:

- Dry powder
 - CO₂
 - Water mist
 - Alcohol resistant foam
-

User inspection (checklist)

The inspection checklist is designed for users to perform the preventive maintenance. No special skills are required for this service check. The check list contains information about:

- which components must be inspected
 - frequency of inspection (**Yearly**, **Monthly**, **Weekly**, **Daily**)
 - how to perform inspection
 - Criteria for acceptance or non-acceptance
-

Annual or according to service counter

When the service interval expires, or at least once annually, deliver the dehumidifier to an authorised service centre.

The machine will be thoroughly serviced and inspected, checked for leaks in the cooling system and electrical safety.

Dantherm also provides fixed service contracts which cover an 18 point service programme. Contact your nearest Dantherm dealer for more details.

Contact Dantherm for a specific checklist for skilled and authorised professionals.

Spare parts

Find our webshop with spare parts for the CDT-dehumidifiers on Dantherm.com.

Preventive maintenance, *cont.*

Checklist (User) - page 1

What	Frequency	How to	Criteria	✓	÷	X
User manual: Is the user manual available in the local language	D	Visually	Acceptance: User manual available			
Marking						
Type plate	Y	Visually	Acceptance: Markings are readable.			
Item no.	Y	Check that all markings are readable and in original form – without any damages or alterations.	Non-acceptance: The markings must be replaced, if they are damaged, altered or unreadable.			
Inspection marking	Y					
Warnings	Y					
Electrical equipment: Supply cord						
Plug and cable	M	Visually. Check that plug and cables are without any damages or fractures.	Acceptance: No damages or fractures on plug and cables.			
PE-plug (earthing)/ adapter	M	Visually Check that the connector on the cable fits to the supply plug.	Acceptance: The connector fits to the supply plug or is equipped with an adapter.			
Electrical equipment: Internal cabling (Take care of hot surfaces! Remove front grille and inspect cables inside the unit.)						
Mounting	Y	Visually Check that all connections are fixed and mounted correctly onto the terminals.	Acceptance: Cables are fitted into terminals.			
Plug and cables	Y	Visually Check that plugs and cables are without any damages or fractures.	Acceptance: No damages or fractures on plugs and cables.			

Preventive maintenance, *cont.*

Checklist (User)
- page 2

What	Frequency	How to	Criteria	✓	÷	X
Does operation hour counter work?	Y	Visually	Acceptance: Start dehumidifier, check that hour counter is working.			
Does the MED-counter work?	Y	Visually	Acceptance: Start dehumidifier, check that MED-counter measures the power consumption.			
Display	Y	Visually	Acceptance: Light in display. Display is readable.			
The casing of the dehumidifier						
Cleaning	M	Visually	Acceptance: Clean, free of oil and dirt.			
Free passage through ventilation openings	M	Visually	Acceptance: Ventilation openings are free of dust and dirt.			
Deformations, cracks or fractures	Y	Visually Measuring tape	Acceptance: Deformation < 5 mm deep. Openings between plates < 5 mm.			
Fixation and damage of handle	Y	Manual check	Acceptance: No loose or missing screws. No obvious damages on handle. The handle slides up and down easily. The handle cannot slide up and down, when thumbscrews are tightened.			
Gaskets and sealings	Y	Visually	Acceptance: Gaskets are complete and without any cracks.			
Visual check of the wheels	Y	Visually	Acceptance: Wheels run freely - without hindrance. No obvious damages on the track of the wheels.			

Preventive maintenance, *cont.*

Checklist (User) - page 3

What	Frequency	How to	Criteria	✓	÷	X
Front and rear grille (function and fixation)	Y	Visually	Acceptance: The filter is mounted. The exhaust grille or exhaust plate (S-module) is mounted and fixed with 4 screws. The grid within the exhaust air wholes on the CDT 30S and CDT 40S are complete			
Collecting the water						
Is the water container ok?	Y	Fill up with water and check that water is not escaping the container.	Acceptance: No leaks			
Is the float working correctly?	Y	Water container is removed during operation. The dehumidifier has to stop operation.	Acceptance: The dehumidifier stops operation after 10 sec. Non-acceptance: The dehumidifier do not stop and continues operation.			
Is the drain outlet from the drip tray ok?	Y	Fill up with water and check that water flows out of the drain outlet.	Acceptance: Free passage through drain outlet.			
Does the pump work correctly?	Y	Fill up with water, start the dehumidifier and check that the pump starts and empties the container.	Acceptance: The pump starts and empties container.			
Control buttons: Start/ stop	M	Press to start dehumidifier and press to switch off again.	Acceptance for starting: The dehumidifier starts up after 2 sec. Acceptance for switching off: The dehumidifier switches off after 2 sec.			

Preventive maintenance, *cont.*

Checklist (User)
- page 4

What	Frequency	How to	Criteria	✓	÷	X
Cooling circuit						
Is the insulation ok?	Y	Visually	Acceptance: Insulation is complete and without any wholes or cracks.			
Leaks on pipes	Y	Are the pipes undamaged and without any corrosion? Is oil gathered at the bottom of the compressor? Are there other signs of leakages at the compressor or within the cooling circuit?	Acceptance: Pipes are undamaged, without corrosion or dents. No oil gathered at the bottom of the compressor.			
Does the cooling circuit work?	Y	Start dehumidifier and control that the surfaces are getting cold.	Acceptance: Surfaces are getting cold.			
Are the heating/ cooling surfaces clean?	Y	Remove air filter and inspect heating/ cooling surfaces visually.	Dirty surfaces are cleaned with a soft brush.			
Are slats without any damages?	Y	Remove air filter and inspect visually.	Bent slats are straightened out.			
Ventilation						
Are fans clean?	Y	Visually	Acceptance: Clean, free of oil and dirt.			
Does the fan run freely - without hindrance?	Y	Visually	Acceptance: Fan is running freely - without hindrance - when turned by			
Are filters clean and without damages?	Y	Visually	Acceptance: Clean, free of oil and dirt.			

Preventive maintenance, *cont.*

Monthly cleaning Procedure for monthly cleaning:

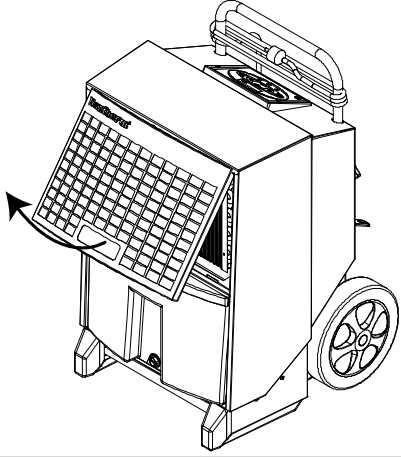
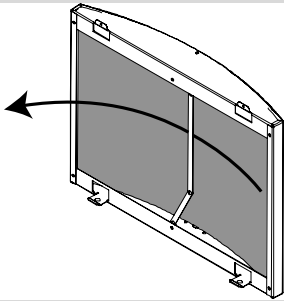
Step	Action	
1	Open and lift up the front grille	
2	Remove the filter and rinse in warm soapy water, or vacuum clean if only slightly dirty If the filter is very dirty, it should be replaced. See the section on spare parts	
3	Clean the water container	

Continued on next page

Preventive maintenance, *cont.*

Monthly cleaning,
cont.

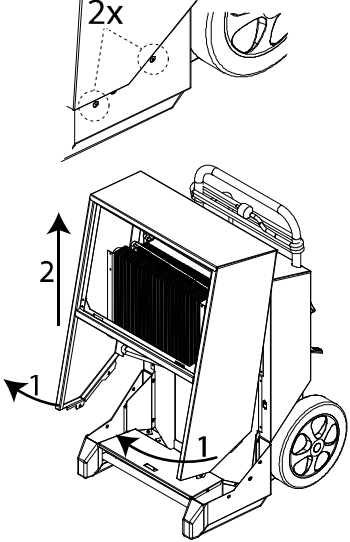
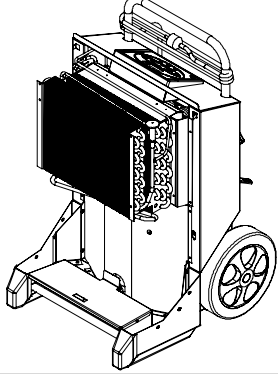
Step	Action	Action
<p>4</p> <p>Remove the 2 screws on each side, and raise the cover about 30° Lift cover up</p> <p>WARNING: Be aware of sharp edges.</p>		
<p>5</p> <p>Clean the evaporator surface with a soft brush, vacuum cleaner or compressed air</p> <p>Replace the cover and water container</p> <p>WARNING: Be aware of sharp edges.</p>		
<p>6</p>	<p>DO NOT reset the units service interval counter when performing monthly service</p>	

Troubleshooting

Troubleshooting

Use the table below to localise and correct problems or errors:

Problem	Possible cause	Solution
<ul style="list-style-type: none"> Dehumidifier will not start Display not switched on 	Plug not in mains socket	Check dehumidifier is connected to the mains. Check the mains socket if necessary by connecting another electrical appliance
<ul style="list-style-type: none"> Dehumidifier will not start Green light not on HYG STOP shown on display 	The hygrostat has measured air humidity lower than the set point, and switched off to save power	Reduce hygrostat set point, or switch to manual operation. See the section on Internal hygrostat operation page 12
<ul style="list-style-type: none"> Yellow light on Display shows Full 	Container full or pump (accessory) blocked	Empty water container or clear pump blockage
<ul style="list-style-type: none"> Red light on 	Error stopping the machine	See user guide table on page 15 on error messages
<ul style="list-style-type: none"> Dehumidifier running Green light on SERVICE flashing on display 	Service interval set has expired	Service the product as specified in the section on service counter expiry
<ul style="list-style-type: none"> Dehumidifier running When RH% activates, the display shows SENSOR FAIL 	RH% sensor defective	Replace RH% sensor
<ul style="list-style-type: none"> kWh and hours without power not displayed 	Memory battery flat.	Replace battery. See page 14

Note:

- If the machine is not working properly, switch off immediately!
- Before starting troubleshooting, wait for one minute, as the electronics could have cut off the machine for safety reasons

Additional help

If the dehumidifier will not restart, contact your Dantherm dealer. This also applies if the machine runs without condensing any water. There may be a fault on the cooling circuit which will require a service technician

Disposal

Warning

This product is designed to last for many years. When disposing the product, observe all national laws and procedures for protection of the environment.

Evacuate refrigerant

This product contains flammable refrigerant.
Before disposing evacuate refrigerant according to below procedure:

Action	
1	Isolate system electrically.
2	Before attempting the procedure ensure that: <ul style="list-style-type: none"> • Mechanical handling equipment is available, if required, for handling refrigerant cylinders. • All personal protective equipment is available and being used correctly. • The recovery process is supervised at all times by a competent person. • Recovery equipment and cylinders conform to the appropriate standard.
3	Use only appropriate refrigerant recover cylinders and make sure that they are situated on the scales before recovery takes place. <ul style="list-style-type: none"> • Do not mix refrigerants in recovery units and especially not in cylinders.
4	Start the recovery machine and operate in accordance with manufacturer's instructions. <ul style="list-style-type: none"> • Do not overfill cylinders. (No more than 80 % volume liquid charge). • Do not exceed the maximum working pressure of the cylinder, even temporarily.
5	When the cylinders have been filled correctly and the process has been completed, put on a label stating that the system is: <ul style="list-style-type: none"> • Decommissioned • Emptied of refrigerant • Ensure that there are labels on the equipment stating the equipment contains flammable refrigerant The label must be dated and signed by the responsible technician.
5	Make sure that the cylinders and the equipment are removed from site promptly and all isolation valves on the equipment are closed off.
6	Recovered refrigerant shall be returned to the refrigerant supplier. <ul style="list-style-type: none"> • Do not charge recovered refrigerant into another refrigeration system unless it has been cleaned and checked.

Batteries/ Electronics

Electrical and electronic appliances and their batteries contain materials, components and substances which can be harmful to human health and to the environment if refuse is not handled correctly.

Electrical and electronic appliances and batteries are labelled with a crossed-over rubbish bin. This symbolises that electric and electronic appliances and batteries cannot be disposed of with unsorted domestic refuse, but must be collected separately.

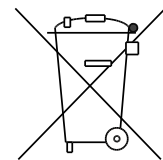

As a consumer, it is important that you hand in used batteries to an approved collection point. This will help ensure that batteries are recycled in accordance with the law, and will not harm the environment needlessly.

Appendix

Technical data

General data

The table below shows the general technical data:

Data	unit	CDT 30S	CDT 40S
Range - humidity	%RH	40-100	
%RH hysteresis	%RH	4	
Range - temperature	°C	3-35	
Mains connection	V/Hz	1N 230+PE/50	
Duct connections	mm	Ø100	
Max. ampere rating	A	7.9	8.4
Max. effect consumed with heating element	kW	1.8	1.9
Air production	m ³ /h	350/300*	560/460*
Refrigerant	-	R454C	
Refrigerant filling	kg	0.41	0.45
GWP (Global Warming Potential)	-	146	
Water container capacity	l	7.0	14.0
Noise level at 1 m distance	dB	60**	62**
Weight	kg	34	42
Protection class	IP	x4	
Filter	PPI	15	
kWh accuracy	%	±5 %	
*) Free-blowing/through 5m hose **) with airducts mounted			

Dimensions

Illustration

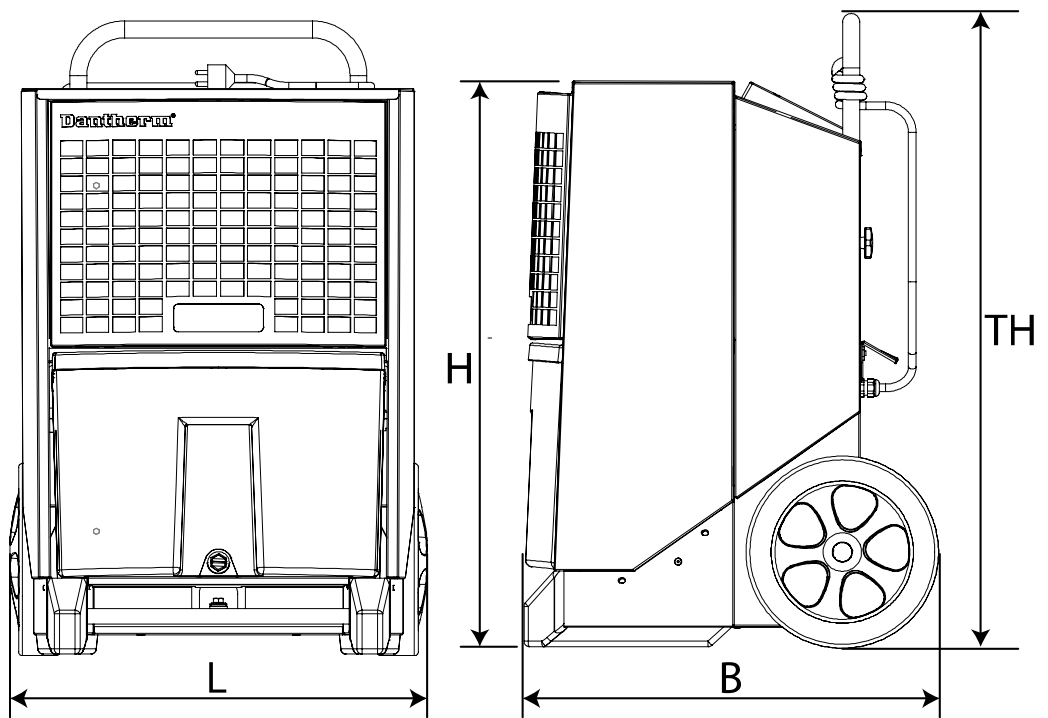

	CDT 30S MK III	CDT 40S MK III
L	426 mm	542 mm
B	506 mm	539 mm
H	650 mm	736 mm
TH	1016 mm	1190 mm

Wiring diagram

Diagram

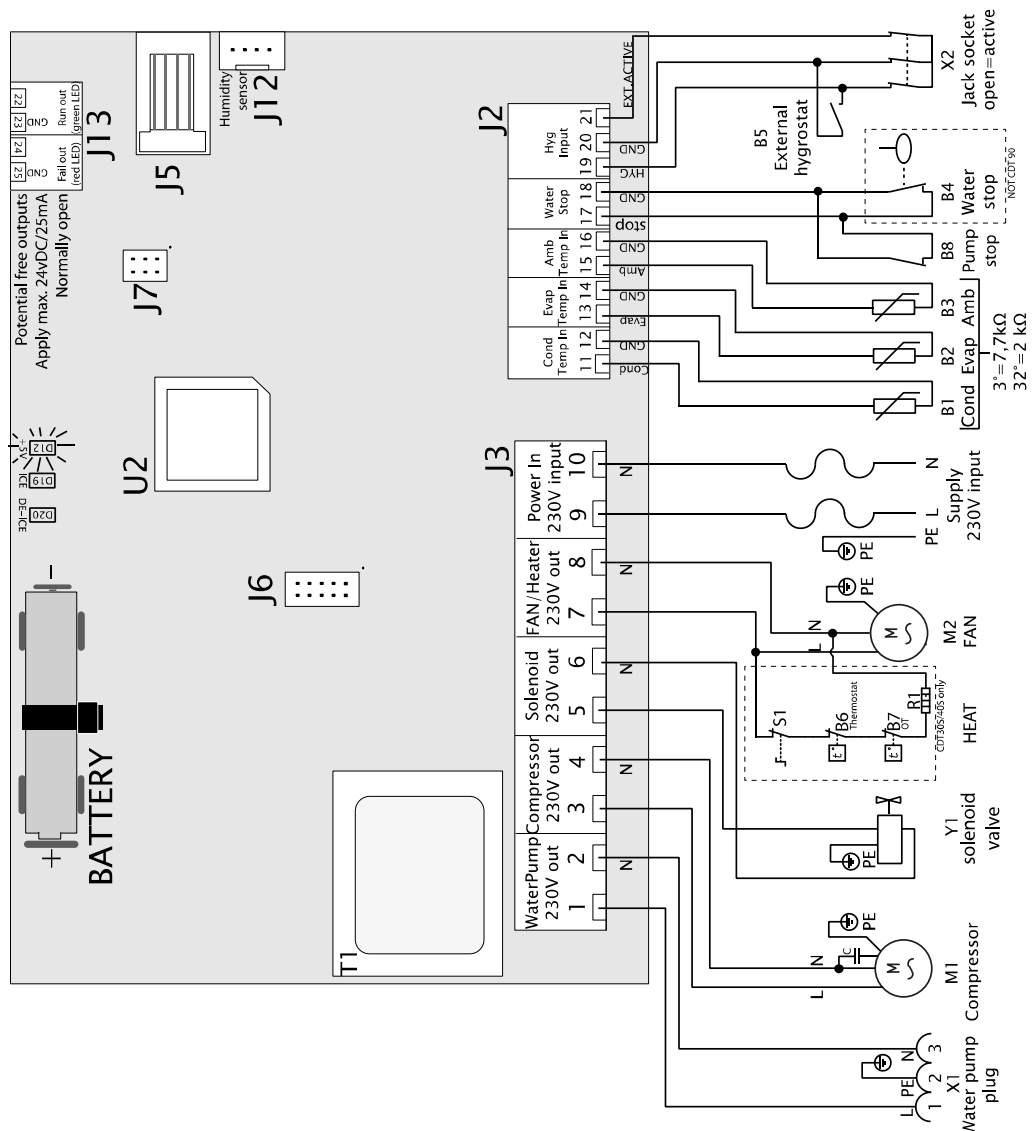

Pos.	Description	Pos.	Description
B1	Condenser surface temperature sensor	J6	Not in use
B2	Evaporator surface temperature sensor	J7	Factory settings
B3	Ambient temperature sensor	J12	Internal hygrostat
B4	"Full water tank" sensor	J13	Extra output
B5	External hygrostat (accessory)	M1	Cooler compressor
B6	Thermostat (30S/40S only)	M2	Fan motor
B7	OT (30S/40S only)	R1	Heating element (30S/40S only)
B8	External pump alarm (accessory)	S1	Heating element on/off (30S/40S only)
D12	LED +5V DC supply control	T1	Transformer
D19	LED Ice on evaporator surface	U2	CPU
D20	LED Defrosting active	X1	Water pump plug
J2	Low voltage connections	X2	Jack plug for external hygrostat
J3	230V connections	Y1	Solenoid valve
J5	Not in use		

Declaration of Conformity

EU declaration
of compliance



Dantherm, Marienlystvej 65, DK-7800 Skive hereby declare that the air dehumidifiers mentioned below:

Type: CDT 30, CDT 40, CDT 60, CDT 90 MKIII
No.: 351110, 351112, 351114, 351115

- Complies with the following directives:

2006/42/EC	Machinery Directive
2014/30/EU	EMC Directive
2011/65/EU	RoHS Directive
1907/2006/EC	REACH Regulation

- and is manufactured in compliance with the following harmonized standards:

DS/EN ISO 12100:2010	Safety of machinery – General principles for design
EN 60335-1:2012	Household and similar electrical appliances – Safety – Part 1
EN 60335-2-40:2003	Household and similar electrical appliances – Safety – Part 2-40
EN 60335-2-40: A1 2006	Household and similar electrical appliances – Safety – Part 2-40
EN 378-1:2016	Refrigerating systems and heatpumps – Safety and environmental requirements – Part 1
EN 378-2:2016	Refrigerating systems and heatpumps – Safety and environmental requirements – Part 2

Index

battery	26	light	25
control panel.....	6	maintenance.....	18
cooling circuit	6	on/off.....	11
dimensions	28	plug.....	25
Display texts	13	position	8
disposal	26	replacing the memory battery.....	14
ducting connections	5	socket	8
electrical connection	8	stack units.....	10
error messages	15	storage.....	7
function description	4	technical data	27
heating element	5; 11	Text displays when not connected to mains	13
hour counter	12	transport	7
illustration	4	troubleshooting.....	25
internal hygrostat.....	12; 25	wiring diagram	29



Dantherm A/S
Marienlystvej 65
7800 Skive
Denmark

support.dantherm.com



053326

Dantherm can accept no responsibility for possible errors and changes (en)

Der tages forbehold for trykfejl og ændringer (da)

Irrtümer und Änderungen vorbehalten (de)

Dantherm n'assume aucune responsabilité pour erreurs et modifications éventuelles (fr)

